

# B22G5 Technical Data Sheet

Compressor model **B22G5**  
 Voltage **110-115V 60Hz ~1**  
 Refrigerant **R134a**

## APPLICATION

## COMPRESSOR

## MOTOR

Application	High Back Pressure	Displacement	2,20 cm <sup>3</sup>	Nominal Power	1/16 hp
Refrigerant	R134a	Diameter	17,20 mm	Voltage/Frequency	110-115V 60Hz
Evaporating Temp.	-15,0 °C to 10,0 °C	Stroke	9,40 mm	Voltage range	94-127 V
Expansion	Capillar/Valve	Net Weight	4,80 Kg	Type	RSIR
Comp. Cooling	Static/Fan cooled	Oil type	POE 32	Phase number	1 PH
Max. ambient temp.	43,0 °C	Oil charge	130 cm <sup>3</sup>	Locked Rotor Amps (LRA)	4,60 A
Compatible refriger.	R1234yf			Main W. resist. at 25°C	11,40 Q
				Start W. resist. at 25°C	11,40 Q

## NOMINAL PERFORMANCE

	ASHRAE	CECOMAF
Cooling Capacity	194 kCal/h	188 W
COP	2,13 W/W	1,83 W/W
EER	1,83 kCal/Wh	1,58 kCal/Wh
Input Power	106 W	103 W
Current	1,21 A	1,18 A

## TEST CYCLE CONDITIONS

	ASHRAE HBP (D)	CECOMAF HBP (C)
Evaporating temp. (T <sub>e</sub> )	7,2 °C	5,0 °C
Condensing temp. (T <sub>c</sub> )	55,0 °C	55,0 °C
Liquid temp. (T <sub>liq.</sub> )	46,0 °C	55,0 °C
Ambient temp. (T <sub>amb.</sub> )	35,0 °C	32,0 °C
Suction temp. (T <sub>suction</sub> )	35,0 °C	32,0 °C
Voltage/Frequency	115 V 60 Hz	115 V 60 Hz

## ELECTRICAL COMPONENTS

Relay	Option 1	Option 2	Option 3	
Reference	JPQII-4.7 (010)	QP2-4.7 (010)	QP2-4R7 (010)	
Voltage	V	V	V	
Resistance	Q	Q	Q	
Protector	Option 1	Option 2	Option 3	
Reference	BT48-135 (067)	BT48-125A61D2 (067)	DRB18P61A1 (067)	
Current				
Time check				
Disc temp. (Open/Close)				

# B22G5 Technical Data Sheet



## ASHRAE

Tc °C	Te °C	Cooling Capacity kCal/h	Consumption W	Current A	COP W/W	EER kCal/Wh
40	-15	79	64	0,95	1,45	1,25
40	-10	110	69	0,98	1,86	1,60
40	-5	145	74	1,00	2,29	1,97
40	0	185	79	1,03	2,72	2,34
40	5	230	85	1,06	3,16	2,71
40	7,2	251	87	1,08	3,35	2,88
40	10	279	90	1,10	3,60	3,09

45	-15	75	65	0,96	1,35	1,16
45	-10	103	71	0,99	1,68	1,44
45	-5	135	78	1,02	2,02	1,74
45	0	171	84	1,06	2,37	2,04
45	5	212	91	1,10	2,73	2,35
45	7,2	232	93	1,12	2,89	2,48
45	10	258	97	1,14	3,09	2,66

50	-15	72	66	0,97	1,26	1,08
50	-10	96	74	1,00	1,51	1,30
50	-5	124	81	1,04	1,78	1,53
50	0	157	89	1,09	2,06	1,77
50	5	195	96	1,14	2,35	2,02
50	7,2	213	100	1,16	2,49	2,14
50	10	237	104	1,19	2,65	2,28

55	-15	68	68	0,97	1,17	1,00
55	-10	89	76	1,02	1,35	1,16
55	-5	114	85	1,07	1,56	1,34
55	0	144	94	1,12	1,79	1,53
55	5	178	102	1,18	2,02	1,74
55	7,2	194	106	1,21	2,13	1,83
55	10	217	111	1,25	2,27	1,95

60	-15	64	69	0,98	1,08	0,93
60	-10	82	79	1,03	1,20	1,03
60	-5	103	88	1,09	1,36	1,17
60	0	130	98	1,15	1,53	1,32
60	5	160	108	1,22	1,73	1,48
60	7,2	176	112	1,26	1,82	1,56
60	10	196	118	1,30	1,93	1,66

65	-15	61	71	0,99	1,00	0,86
65	-10	74	81	1,05	1,06	0,91
65	-5	93	92	1,11	1,17	1,01
65	0	116	103	1,19	1,31	1,12
65	5	143	114	1,27	1,46	1,26
65	7,2	157	119	1,31	1,53	1,32
65	10	175	125	1,36	1,63	1,40

## CECOMAF

Tc °C	Te °C	Cooling Capacity W	Consumption W	Current A	COP W/W	EER kCal/Wh
40	-15	85	64	0,96	1,34	1,15
40	-10	119	69	0,98	1,72	1,48
40	-5	157	74	1,01	2,11	1,82
40	0	200	80	1,04	2,50	2,16
40	5	247	85	1,07	2,90	2,51
40	7,2	270	88	1,08	3,08	2,66
40	10	300	91	1,10	3,30	2,85

45	-15	81	65	0,96	1,24	1,07
45	-10	110	72	0,99	1,54	1,33
45	-5	145	78	1,03	1,85	1,60
45	0	184	85	1,06	2,17	1,88
45	5	228	91	1,10	2,50	2,16
45	7,2	248	94	1,12	2,64	2,28
45	10	276	98	1,15	2,83	2,44

50	-15	76	67	0,97	1,14	0,99
50	-10	102	74	1,01	1,38	1,19
50	-5	132	82	1,05	1,62	1,40
50	0	168	89	1,09	1,88	1,62
50	5	208	97	1,14	2,14	1,85
50	7,2	227	100	1,17	2,26	1,95
50	10	253	105	1,20	2,41	2,08

55	-15	72	68	0,98	1,06	0,91
55	-10	94	77	1,02	1,22	1,06
55	-5	120	85	1,07	1,41	1,22
55	0	152	94	1,12	1,61	1,39
55	5	188	103	1,18	1,83	1,58
55	7,2	205	107	1,21	1,92	1,66
55	10	229	112	1,25	2,05	1,77

60	-15	68	70	0,98	0,97	0,84
60	-10	85	79	1,03	1,08	0,93
60	-5	108	89	1,09	1,22	1,05
60	0	136	99	1,16	1,37	1,19
60	5	168	109	1,23	1,54	1,33
60	7,2	184	113	1,26	1,62	1,40
60	10	205	119	1,31	1,73	1,49

65	-15	63	71	0,99	0,89	0,77
65	-10	77	82	1,05	0,94	0,81
65	-5	96	93	1,11	1,04	0,89
65	0	120	104	1,19	1,15	1,00
65	5	148	115	1,27	1,29	1,12
65	7,2	162	120	1,31	1,36	1,17
65	10	181	126	1,37	1,44	1,25

## EN12900

X	Cooling Capacity (W)	Consumption (W)	Current (A)	Mass Flow (kg/h)
1	328,0571885797	42,5424792048	0,7741754557	5,7452136615229
2	15,2555519521	-0,6925251365	-0,0068459483	0,29330210525282
3	-3,2752831078	0,9811978458	0,0066518817	-0,033748175338737
4	0,0946997061	0,0027081304	0,0001288892	0,0028385677886559
5	-0,1572155853	0,0457488166	0,0003492764	-0,002035792648791

Equation	$x_1 + x_2Te + x_3Tc + x_4Te^2 + x_5TeTc$
----------	---

# B22G5 Technical Data Sheet

## COMPRESSOR DIMENSIONS

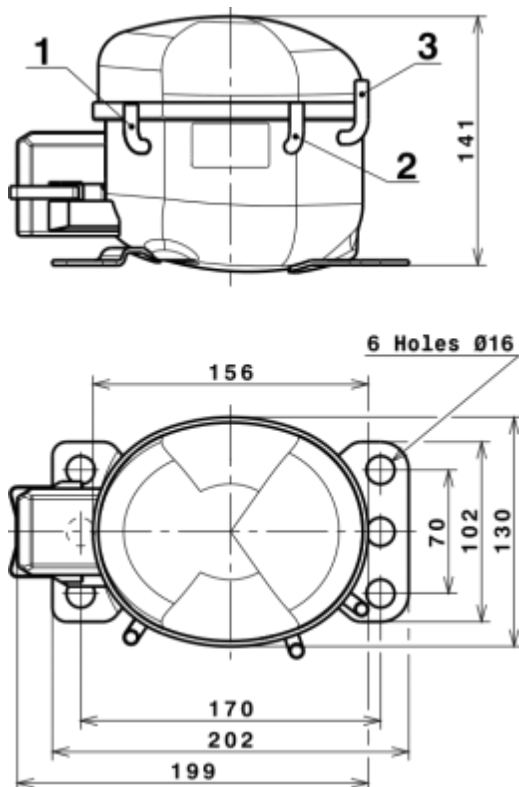

## DESIGNATION INTERNAL DIAM.

DESIGNATION	INTERNAL DIAM.
1 Suction	6,1 mm
2 Service	6,1 mm
3 Discharge	5,1 mm

## WIRING DIAGRAMS AND ELECTRICAL ASSEMBLY

### RSIR CONNECTION (PTC) (B, Small L ranges)

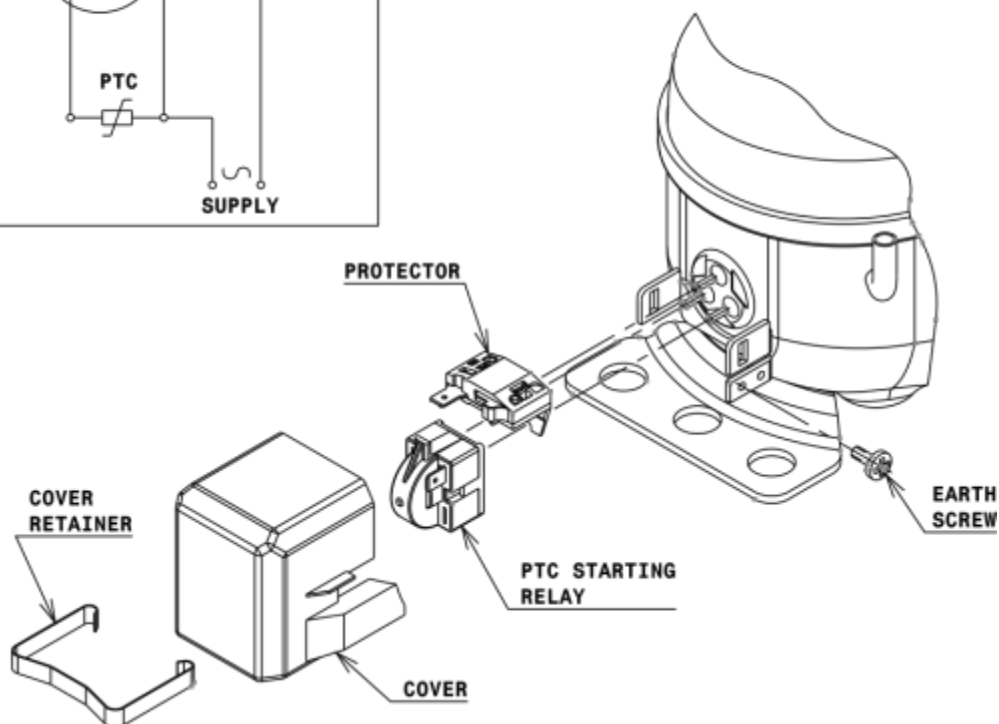
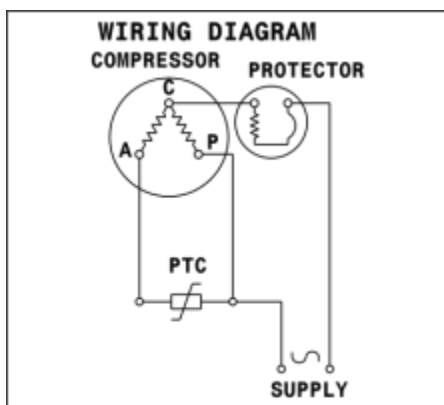

# B22G5 Technical Data Sheet

## FIXINGS

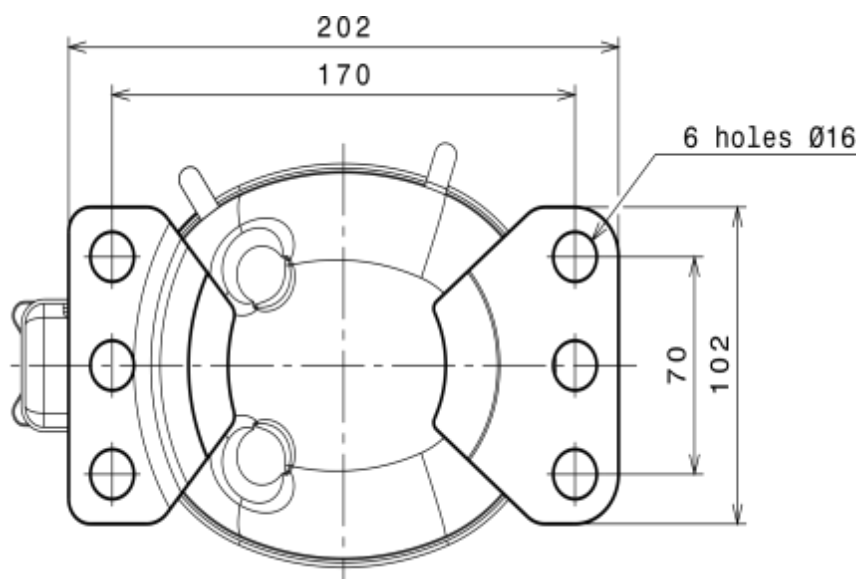

## SILENT BLOCKS (MOUNTING ACCESSORIES)

### STANDARD

16 holes (170x70 net)

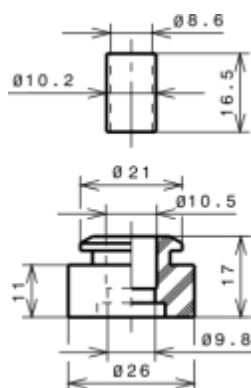

## SOA

SOA R134a HBP

