

B30N Technical Data Sheet

Compressor model **B30N**
 Voltage **220-240V 50Hz ~1**
 Refrigerant **R290**

APPLICATION

COMPRESSOR

MOTOR

Application	High-Medium Back Pressure	Displacement	3,10 cm ³	Nominal Power	1/10 hp
Refrigerant	R290	Diameter	17,20 mm	Voltage/Frequency	220-240V 50Hz
Evaporating Temp.	-25,0 °C to 10,0 °C	Stroke	13,40 mm	Voltage range	187-255 V
Expansion	Capillar/Valve	Net Weight	5,80 Kg	Type	CSIR
Comp. Cooling	Fan cooled	Oil type	ISO VG 32 ESTER	Phase number	1 PH
Max. ambient temp.	43,0 °C	Oil charge	120 cm ³	Locked Rotor Amps (LRA)	6,50 A
				Main W. resist. at 25°C	16,50 Q
				Start W. resist. at 25°C	23,60 Q

NOMINAL PERFORMANCE

	ASHRAE	CECOMAF
Cooling Capacity	364 kCal/h	354 W
COP	2,61 W/W	2,21 W/W
EER	2,25 kCal/Wh	1,91 kCal/Wh
Input Power	162 W	160 W
Current	1,15 A	1,14 A

TEST CYCLE CONDITIONS

	ASHRAE HMBP (D)	CECOMAF HMBP (C)
Evaporating temp. (T _e)	7,2 °C	5,0 °C
Condensing temp. (T _c)	55,0 °C	55,0 °C
Liquid temp. (T _{liq.})	46,0 °C	55,0 °C
Ambient temp. (T _{amb.})	35,0 °C	32,0 °C
Suction temp. (T _{suction})	35,0 °C	32,0 °C
Voltage/Frequency	220 V 50 Hz	220 V 50 Hz

ELECTRICAL COMPONENTS

Starting capacitor	50 pF 330 V			
Relay	Option 1			
Reference	QL2-3.3 B3 (012)			
Pick-Up	3.3 A			
Drop-Out	2.6 A			
Protector	Option 1			
Reference	DRB20S61A2 (070)			
Current				
Time check				
Disc temp. (Open/Close)				

B30N Technical Data Sheet

ASHRAE

Tc °C	Te °C	Cooling Capacity kCal/h	Consumption W	Current A	COP W/W	EER kCal/Wh
40	-25	124	103	1,01	1,39	1,20
40	-20	155	109	1,02	1,66	1,42
40	-15	194	114	1,03	1,97	1,69
40	-10	239	119	1,04	2,33	2,01
40	-5	291	123	1,05	2,74	2,36
40	0	349	127	1,06	3,21	2,76
40	5	414	129	1,06	3,72	3,20
40	7,2	445	131	1,06	3,97	3,41
40	10	486	132	1,07	4,29	3,69

45	-25	114	105	1,01	1,26	1,09
45	-20	143	112	1,03	1,48	1,27
45	-15	179	119	1,04	1,75	1,50
45	-10	221	125	1,05	2,06	1,77
45	-5	270	130	1,06	2,41	2,07
45	0	326	135	1,08	2,80	2,41
45	5	388	139	1,09	3,24	2,79
45	7,2	418	141	1,09	3,45	2,96
45	10	457	143	1,10	3,72	3,20

50	-25	105	107	1,02	1,14	0,98
50	-20	131	116	1,03	1,32	1,13
50	-15	164	124	1,05	1,54	1,33
50	-10	204	131	1,07	1,81	1,55
50	-5	250	138	1,08	2,11	1,81
50	0	303	144	1,10	2,45	2,11
50	5	363	149	1,11	2,82	2,43
50	7,2	391	152	1,12	3,00	2,58
50	10	429	154	1,13	3,24	2,78

55	-25	95	109	1,02	1,01	0,87
55	-20	119	119	1,04	1,16	1,00
55	-15	149	128	1,06	1,35	1,16
55	-10	186	137	1,08	1,58	1,36
55	-5	230	145	1,10	1,84	1,58
55	0	280	152	1,12	2,14	1,84
55	5	337	159	1,14	2,46	2,12
55	7,2	364	162	1,15	2,61	2,25
55	10	400	165	1,16	2,82	2,42

60	-25	86	111	1,02	0,90	0,77
60	-20	106	122	1,05	1,01	0,87
60	-15	134	133	1,07	1,17	1,01
60	-10	168	143	1,10	1,37	1,18
60	-5	209	152	1,12	1,60	1,37
60	0	257	161	1,15	1,85	1,59
60	5	311	169	1,17	2,14	1,84
60	7,2	337	173	1,18	2,27	1,95
60	10	372	177	1,20	2,45	2,11

CECOMAF

Tc °C	Te °C	Cooling Capacity W	Consumption W	Current A	COP W/W	EER kCal/Wh
40	-25	133	104	1,01	1,28	1,11
40	-20	168	110	1,02	1,53	1,32
40	-15	209	115	1,03	1,82	1,57
40	-10	258	120	1,04	2,15	1,86
40	-5	313	124	1,05	2,53	2,18
40	0	376	127	1,06	2,95	2,55
40	5	445	130	1,06	3,42	2,95
40	7,2	478	131	1,07	3,64	3,14
40	10	522	133	1,07	3,94	3,40

45	-25	122	106	1,01	1,16	1,00
45	-20	153	113	1,03	1,36	1,17
45	-15	192	120	1,04	1,60	1,38
45	-10	237	126	1,05	1,89	1,63
45	-5	289	131	1,07	2,21	1,91
45	0	349	136	1,08	2,56	2,21
45	5	415	140	1,09	2,96	2,56
45	7,2	446	142	1,09	3,14	2,72
45	10	488	144	1,10	3,39	2,93

50	-25	111	108	1,02	1,03	0,89
50	-20	139	116	1,03	1,20	1,03
50	-15	174	124	1,05	1,40	1,21
50	-10	217	132	1,07	1,64	1,42
50	-5	266	139	1,08	1,92	1,66
50	0	322	145	1,10	2,22	1,92
50	5	385	150	1,12	2,56	2,21
50	7,2	415	153	1,12	2,72	2,35
50	10	455	155	1,13	2,93	2,53

55	-25	100	110	1,02	0,91	0,79
55	-20	125	120	1,04	1,05	0,90
55	-15	157	129	1,06	1,22	1,05
55	-10	196	138	1,08	1,42	1,23
55	-5	242	146	1,10	1,66	1,43
55	0	295	153	1,12	1,92	1,66
55	5	354	160	1,14	2,21	1,91
55	7,2	383	163	1,15	2,35	2,03
55	10	421	166	1,16	2,53	2,18

60	-25	89	112	1,02	0,80	0,69
60	-20	111	123	1,05	0,90	0,78
60	-15	140	134	1,07	1,04	0,90
60	-10	175	144	1,10	1,22	1,05
60	-5	218	153	1,12	1,42	1,23
60	0	267	162	1,15	1,65	1,43
60	5	324	170	1,18	1,90	1,64
60	7,2	351	174	1,19	2,02	1,75
60	10	387	178	1,20	2,18	1,88

B30N Technical Data Sheet



EN12900

X	Cooling Capacity (W)	Consumption (W)	Current (A)	Mass Flow (kg/h)
1	593,9504792233	59,6146085051	0,8490498362	5,3113352934188
2	18,4341806311	-1,5007492922	-0,0052712278	0,1841780997321
3	-5,5894445876	1,7811133287	0,0052093318	-0,023549167727041
4	0,1363284425	-0,0122543811	0,0000058262	0,0021331880939011
5	-0,1355323386	0,0547894798	0,0001783995	-0,00041311710012303

Equation	$x_1 + x_2Te + x_3Tc + x_4Te^2 + x_5TeTc$
----------	---

B30N Technical Data Sheet

COMPRESSOR DIMENSIONS

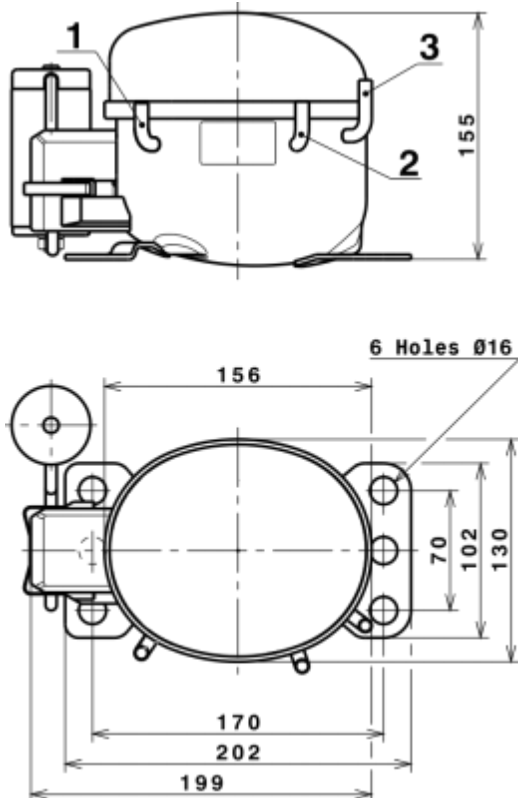

	DESIGNATION	INTERNAL DIAM.
1	Suction	6,1 mm
2	Service	6,1 mm
3	Discharge	5,1 mm

WIRING DIAGRAMS AND ELECTRICAL ASSEMBLY

CSIR CONNECTION (B, Small L ranges)

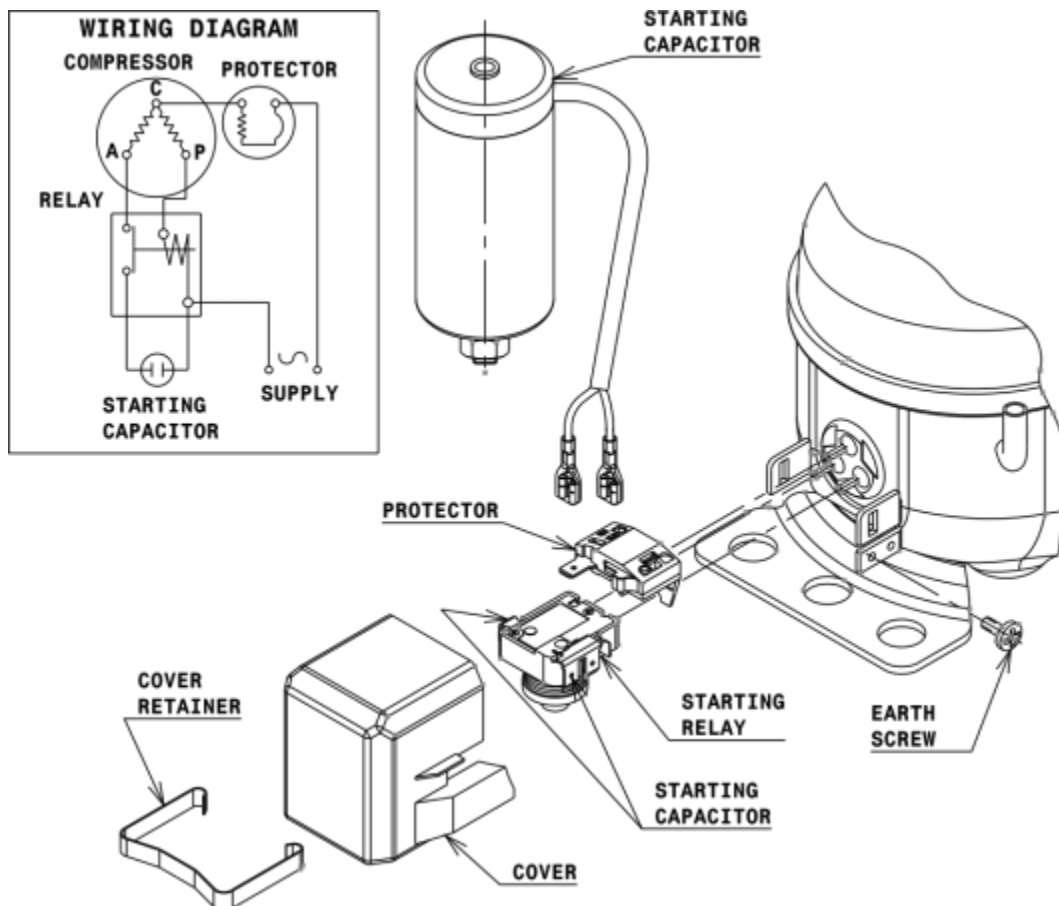

B30N Technical Data Sheet

FIXINGS

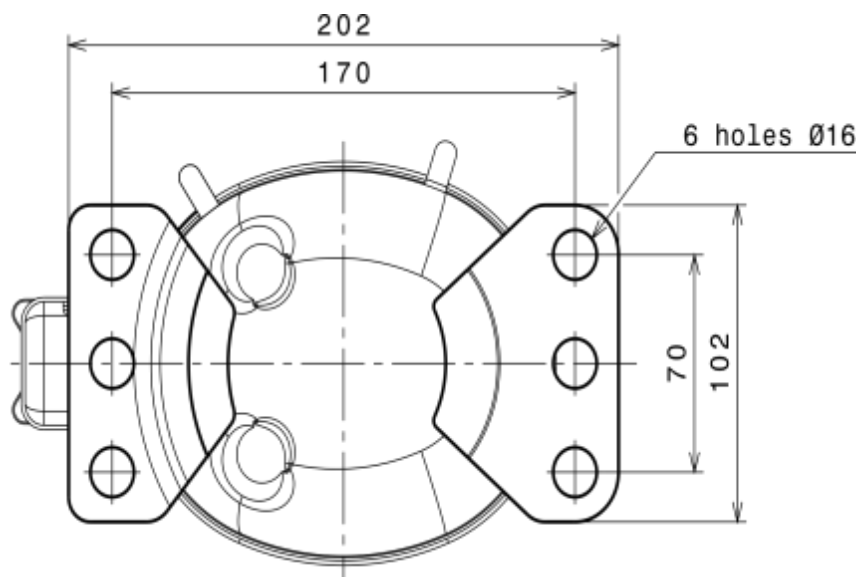

SILENT BLOCKS (MOUNTING ACCESSORIES)

STANDARD

Ø16 holes (170x70 net)

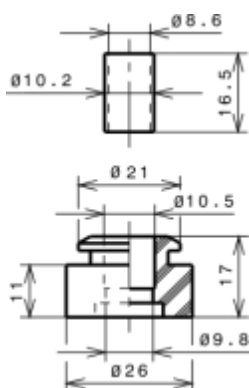

SOA

SOA R290 HMBP

