

B35G5 Technical Data Sheet

Compressor model **B35G5**
 Voltage **110-115V 60Hz ~1**
 Refrigerant **R134a**

APPLICATION

Application High Back Pressure
 Refrigerant R134a
 Evaporating Temp. -15,0 °C to 10,0 °C
 Expansion Capillar/Valve
 Comp. Cooling Static/Fan cooled
 Max. ambient temp. 43,0 °C
 Compatible refriger. R1234yf

COMPRESSOR

Displacement 3,50 cm³
 Diameter 17,20 mm
 Stroke 13,40 mm
 Net Weight 4,90 Kg
 Oil type POE 32
 Oil charge 130 cm³

MOTOR

Nominal Power 1/10 hp
 Voltage/Frequency 110-115V 60Hz
 Voltage range 94-127 V
 Type CSIR
 Phase number 1 PH
 Locked Rotor Amps (LRA) 12,23 A
 Main W. resist. at 25°C 21,90 Q
 Start W. resist. at 25°C 3,85 Q

NOMINAL PERFORMANCE

	ASHRAE	CECOMAF
Cooling Capacity	315 kCal/h	304 W
COP	2,12 W/W	1,80 W/W
EER	1,82 kCal/Wh	1,56 kCal/Wh
Input Power	173 W	169 W
Current	2,37 A	2,34 A

TEST CYCLE CONDITIONS

	ASHRAE HBP (D)	CECOMAF HBP (C)
Evaporating temp. (T _e)	7,2 °C	5,0 °C
Condensing temp. (T _c)	55,0 °C	55,0 °C
Liquid temp. (T _{liq.})	46,0 °C	55,0 °C
Ambient temp. (T _{amb.})	35,0 °C	32,0 °C
Suction temp. (T _{suction})	35,0 °C	32,0 °C
Voltage/Frequency	115 V 60 Hz	115 V 60 Hz

ELECTRICAL COMPONENTS

Starting capacitor	61 pF 330 V			
Relay	Option 1			
Reference	QL2-8.00			
Pick-Up	A			
Drop-Out	A			
Protector	Option 1			
Reference	DRB34V61A1			
Current	12,10 A			
Time check	6-14 seg			
Disc temp. (Open/Close)	150,00 / 61,00 °C			

B35G5 Technical Data Sheet



ASHRAE

Tc °C	Te °C	Cooling Capacity kCal/h	Consumption W	Current A	COP W/W	EER kCal/Wh
40	-15	133	111	2,11	1,39	1,20
40	-10	168	119	2,13	1,65	1,42
40	-5	211	126	2,15	1,94	1,67
40	0	262	135	2,18	2,26	1,95
40	5	321	143	2,21	2,61	2,24
40	7,2	349	147	2,23	2,76	2,38
40	10	388	152	2,25	2,97	2,55

45	-15	127	114	2,11	1,29	1,11
45	-10	160	123	2,14	1,52	1,31
45	-5	202	132	2,17	1,78	1,53
45	0	252	141	2,21	2,07	1,78
45	5	310	151	2,25	2,38	2,05
45	7,2	338	156	2,27	2,52	2,17
45	10	376	161	2,30	2,71	2,33

50	-15	120	117	2,12	1,20	1,03
50	-10	153	127	2,15	1,40	1,20
50	-5	193	137	2,19	1,64	1,41
50	0	242	148	2,24	1,90	1,63
50	5	299	159	2,29	2,18	1,88
50	7,2	326	164	2,32	2,31	1,99
50	10	364	171	2,36	2,47	2,13

55	-15	114	120	2,13	1,11	0,95
55	-10	145	131	2,17	1,29	1,11
55	-5	185	143	2,21	1,50	1,29
55	0	232	155	2,27	1,74	1,50
55	5	288	168	2,34	2,00	1,72
55	7,2	315	173	2,37	2,12	1,82
55	10	352	180	2,42	2,27	1,95

60	-15	107	123	2,14	1,02	0,88
60	-10	138	135	2,18	1,18	1,02
60	-5	176	148	2,24	1,38	1,19
60	0	223	162	2,31	1,60	1,37
60	5	277	176	2,39	1,83	1,58
60	7,2	304	182	2,43	1,94	1,67
60	10	340	190	2,48	2,08	1,79

65	-15	101	125	2,15	0,94	0,80
65	-10	130	140	2,20	1,08	0,93
65	-5	167	154	2,26	1,26	1,09
65	0	213	169	2,34	1,47	1,26
65	5	266	184	2,44	1,68	1,45
65	7,2	292	191	2,48	1,78	1,53
65	10	327	199	2,55	1,91	1,64

CECOMAF

Tc °C	Te °C	Cooling Capacity W	Consumption W	Current A	COP W/W	EER kCal/Wh
40	-15	143	112	2,11	1,28	1,11
40	-10	181	119	2,13	1,52	1,31
40	-5	228	127	2,15	1,79	1,55
40	0	282	135	2,18	2,08	1,80
40	5	346	144	2,22	2,40	2,07
40	7,2	376	148	2,24	2,54	2,20
40	10	417	153	2,26	2,73	2,36

45	-15	136	115	2,12	1,18	1,02
45	-10	172	123	2,14	1,39	1,20
45	-5	217	133	2,17	1,63	1,41
45	0	270	142	2,21	1,90	1,64
45	5	332	152	2,26	2,18	1,88
45	7,2	362	157	2,28	2,31	1,99
45	10	402	163	2,31	2,47	2,14

50	-15	128	117	2,12	1,09	0,94
50	-10	163	128	2,16	1,28	1,10
50	-5	206	138	2,19	1,49	1,29
50	0	258	149	2,24	1,73	1,49
50	5	318	160	2,30	1,98	1,71
50	7,2	347	166	2,33	2,10	1,81
50	10	387	172	2,36	2,25	1,94

55	-15	120	120	2,13	1,00	0,86
55	-10	154	132	2,17	1,17	1,01
55	-5	195	144	2,22	1,36	1,17
55	0	246	156	2,27	1,57	1,36
55	5	304	169	2,34	1,80	1,56
55	7,2	333	174	2,38	1,91	1,65
55	10	371	182	2,42	2,04	1,77

60	-15	113	123	2,14	0,91	0,79
60	-10	144	136	2,19	1,06	0,92
60	-5	185	149	2,24	1,24	1,07
60	0	233	163	2,31	1,43	1,24
60	5	290	177	2,39	1,64	1,42
60	7,2	318	183	2,43	1,74	1,50
60	10	356	191	2,49	1,86	1,61

65	-15	105	126	2,15	0,83	0,72
65	-10	135	140	2,20	0,96	0,83
65	-5	174	155	2,27	1,12	0,97
65	0	221	170	2,35	1,30	1,12
65	5	277	185	2,45	1,49	1,29
65	7,2	304	192	2,49	1,58	1,37
65	10	341	201	2,56	1,70	1,47

EN12900

X	Cooling Capacity (W)	Consumption (W)	Current (A)	Mass Flow (kg/h)
1	382,7868325650	82,4065307194	1,8885861129	5,9032677178785
2	14,4019947252	-0,4235874352	-0,0071067280	0,24250741148327
3	-2,6051928238	1,4124328878	0,0074011800	0,0071593420388618
4	0,1667290085	0,0087054570	0,0002332708	0,004943353787537
5	-0,0682145367	0,0548334463	0,0003809466	0,00090598624043742

Equation	$x_1 + x_2Te + x_3Tc + x_4Te^2 + x_5TeTc$
----------	---

B35G5 Technical Data Sheet

COMPRESSOR DIMENSIONS

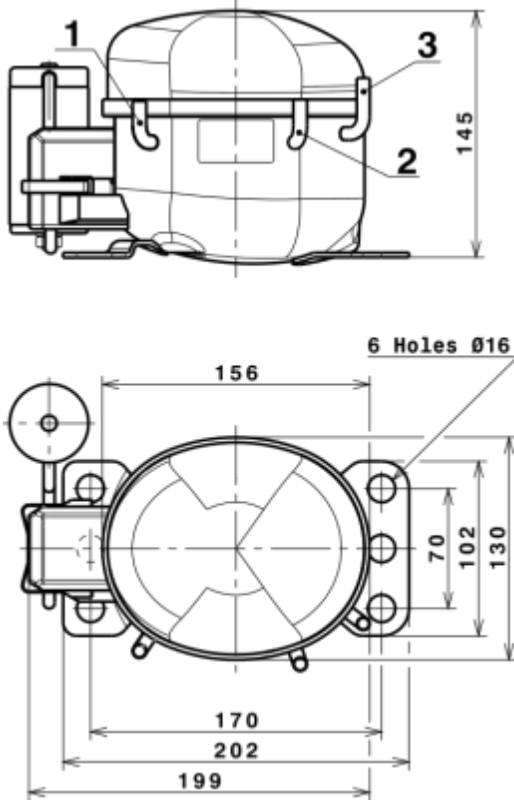

DESIGNATION INTERNAL DIAM.

DESIGNATION	INTERNAL DIAM.
1 Suction	6,1 mm
2 Service	6,1 mm
3 Discharge	5,1 mm

WIRING DIAGRAMS AND ELECTRICAL ASSEMBLY

CSIR CONNECTION (B, Small L ranges)

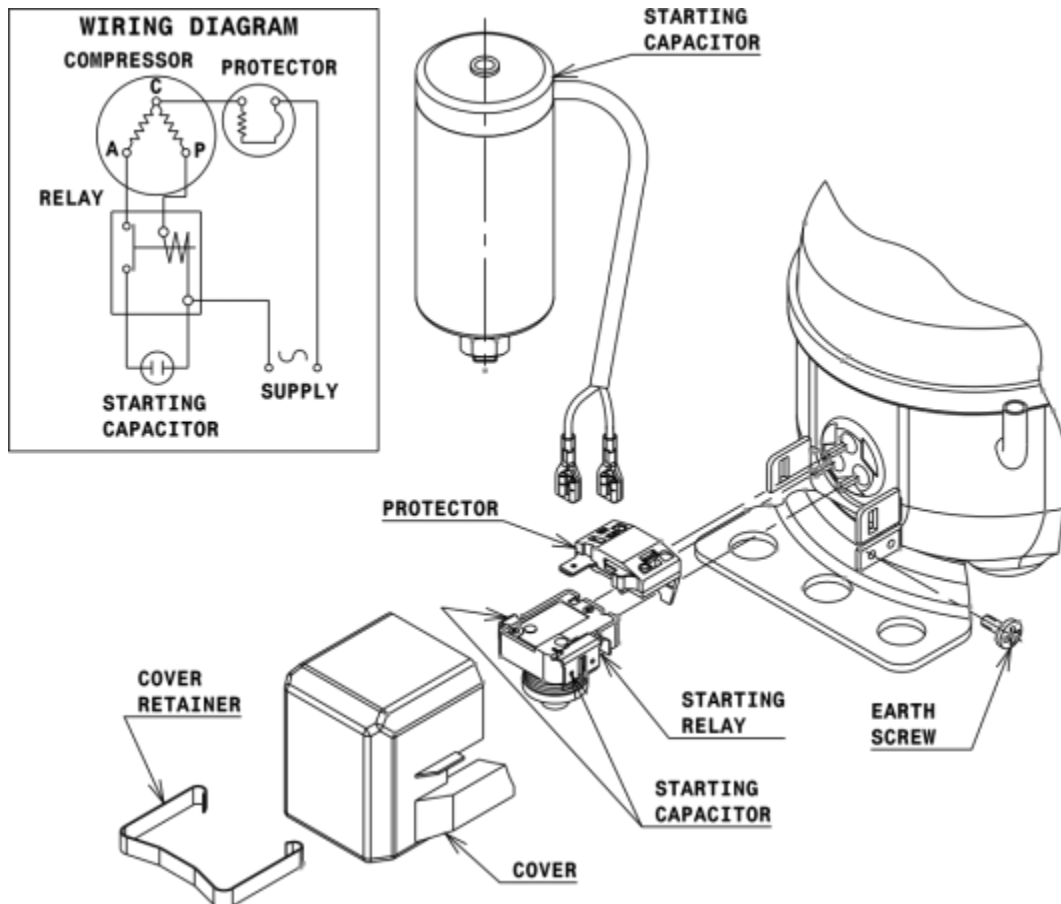

B35G5 Technical Data Sheet

FIXINGS

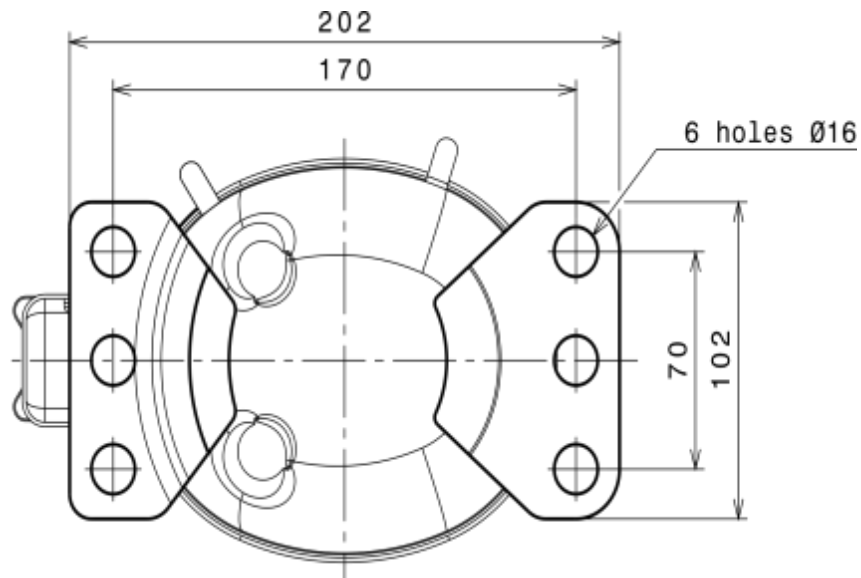

SILENT BLOCKS (MOUNTING ACCESSORIES)

STANDARD

Ø16 holes (170x70 net)

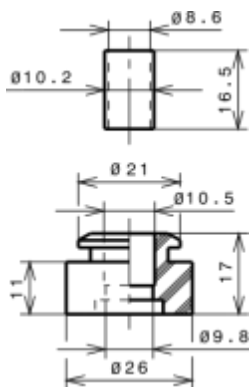

SOA

SOA R134a HBP

