

B38G5L Technical Data Sheet

Compressor model **B38G5L**
 Voltage **110-115V 60Hz ~1**
 Refrigerant **R134a**

APPLICATION

Application High Back Pressure
 Refrigerant R134a
 Evaporating Temp. -15,0 °C to 10,0 °C
 Expansion Capillar/Valve
 Comp. Cooling Static/Fan cooled
 Max. ambient temp. 43,0 °C
 Compatible refriger. R1234yf

COMPRESSOR

Displacement 3,80 cm³
 Diameter 19,00 mm
 Stroke 13,40 mm
 Net Weight 5,50 Kg
 Oil type POE 32
 Oil charge 130 cm³

MOTOR

Nominal Power 1/8 hp
 Voltage/Frequency 110-115V 60Hz
 Voltage range 94-127 V
 Type CSIR
 Phase number 1 PH
 Locked Rotor Amps (LRA) 12,10 A
 Main W. resist. at 25°C 19,70 Q
 Start W. resist. at 25°C 4,20 Q

NOMINAL PERFORMANCE

	ASHRAE	CECOMAF
Cooling Capacity	363 kCal/h	353 W
COP	2,13 W/W	1,83 W/W
EER	1,83 kCal/Wh	1,59 kCal/Wh
Input Power	199 W	192 W
Current	2,48 A	2,44 A

TEST CYCLE CONDITIONS

	ASHRAE HBP (D)	CECOMAF HBP (C)
Evaporating temp. (T _e)	7,2 °C	5,0 °C
Condensing temp. (T _c)	55,0 °C	55,0 °C
Liquid temp. (T _{liq.})	46,0 °C	55,0 °C
Ambient temp. (T _{amb.})	35,0 °C	32,0 °C
Suction temp. (T _{suction})	35,0 °C	32,0 °C
Voltage/Frequency	115 V 60 Hz	115 V 60 Hz

ELECTRICAL COMPONENTS

Starting capacitor	61 pF 330 V			
Relay	Option 1			
Reference	QL2-5.3			
Pick-Up	A			
Drop-Out	A			
Protector	Option 1			
Reference	DRB34V61A1			
Current	12,10 A			
Time check	6-14 seg			
Disc temp. (Open/Close)	150,00 / 61,00 °C			

B38G5L Technical Data Sheet



ASHRAE

Tc °C	Te °C	Cooling Capacity kCal/h	Consumption W	Current A	COP W/W	EER kCal/Wh
40	-15	162	123	2,11	1,54	1,32
40	-10	212	132	2,15	1,87	1,61
40	-5	268	142	2,18	2,20	1,89
40	0	330	152	2,23	2,53	2,17
40	5	399	163	2,28	2,85	2,45
40	7,2	431	168	2,30	2,99	2,57
40	10	474	175	2,34	3,16	2,72

45	-15	151	125	2,12	1,40	1,21
45	-10	198	136	2,16	1,69	1,46
45	-5	252	148	2,21	1,98	1,70
45	0	311	160	2,26	2,27	1,95
45	5	377	172	2,33	2,55	2,19
45	7,2	408	178	2,36	2,67	2,29
45	10	450	186	2,40	2,82	2,42

50	-15	140	128	2,13	1,27	1,10
50	-10	184	140	2,18	1,53	1,31
50	-5	235	154	2,23	1,78	1,53
50	0	292	167	2,30	2,03	1,75
50	5	356	182	2,38	2,28	1,96
50	7,2	386	188	2,42	2,38	2,05
50	10	426	197	2,47	2,52	2,16

55	-15	129	130	2,14	1,15	0,99
55	-10	171	145	2,19	1,37	1,18
55	-5	219	160	2,26	1,60	1,37
55	0	273	175	2,34	1,82	1,56
55	5	334	191	2,43	2,03	1,75
55	7,2	363	199	2,48	2,13	1,83
55	10	401	208	2,54	2,24	1,93

60	-15	118	133	2,15	1,03	0,89
60	-10	157	149	2,21	1,23	1,05
60	-5	203	166	2,29	1,42	1,22
60	0	254	183	2,38	1,62	1,39
60	5	313	201	2,49	1,81	1,56
60	7,2	340	209	2,55	1,90	1,63
60	10	377	219	2,62	2,00	1,72

65	-15	107	135	2,16	0,92	0,79
65	-10	143	153	2,23	1,09	0,94
65	-5	186	172	2,32	1,26	1,09
65	0	235	191	2,43	1,44	1,24
65	5	291	210	2,56	1,61	1,39
65	7,2	317	219	2,62	1,69	1,45
65	10	353	230	2,71	1,78	1,53

CECOMAF

Tc °C	Te °C	Cooling Capacity W	Consumption W	Current A	COP W/W	EER kCal/Wh
40	-15	174	123	2,12	1,42	1,22
40	-10	228	132	2,15	1,72	1,49
40	-5	289	142	2,19	2,03	1,75
40	0	356	153	2,23	2,33	2,01
40	5	430	164	2,28	2,62	2,26
40	7,2	464	169	2,31	2,74	2,37
40	10	510	176	2,34	2,90	2,51

45	-15	162	126	2,13	1,29	1,11
45	-10	212	137	2,16	1,55	1,34
45	-5	270	148	2,21	1,82	1,57
45	0	334	161	2,27	2,08	1,79
45	5	404	173	2,33	2,33	2,01
45	7,2	437	179	2,36	2,44	2,11
45	10	481	187	2,41	2,57	2,22

50	-15	149	128	2,13	1,16	1,00
50	-10	196	141	2,18	1,39	1,20
50	-5	251	154	2,24	1,62	1,40
50	0	311	168	2,30	1,85	1,60
50	5	379	183	2,38	2,07	1,79
50	7,2	410	190	2,42	2,16	1,87
50	10	452	198	2,48	2,28	1,97

55	-15	136	131	2,14	1,04	0,90
55	-10	181	145	2,20	1,24	1,07
55	-5	231	160	2,26	1,44	1,25
55	0	289	176	2,35	1,64	1,42
55	5	353	192	2,44	1,83	1,59
55	7,2	383	200	2,49	1,92	1,66
55	10	424	209	2,55	2,02	1,75

60	-15	123	133	2,15	0,92	0,80
60	-10	165	150	2,22	1,10	0,95
60	-5	212	167	2,29	1,28	1,10
60	0	267	184	2,39	1,45	1,25
60	5	328	202	2,50	1,62	1,40
60	7,2	356	210	2,56	1,70	1,47
60	10	395	220	2,63	1,79	1,55

65	-15	111	136	2,16	0,81	0,70
65	-10	149	154	2,23	0,97	0,83
65	-5	193	173	2,33	1,12	0,97
65	0	244	192	2,44	1,27	1,10
65	5	302	211	2,57	1,43	1,23
65	7,2	330	220	2,63	1,50	1,29
65	10	366	232	2,72	1,58	1,37

EN12900

X	Cooling Capacity (W)	Consumption (W)	Current (A)	Mass Flow (kg/h)
1	535,6985552540	93,1287250891	1,8614703567	8,9790747785473
2	19,3450916779	-0,5793173506	-0,0081315213	0,34042188425706
3	-4,6160708790	1,5928202560	0,0092726601	-0,028536855018028
4	0,1306812859	0,0137781838	0,0003107425	0,0040845630916251
5	-0,1352771435	0,0709750699	0,0004970141	-0,00024087282821328

Equation	$x_1 + x_2Te + x_3Tc + x_4Te^2 + x_5TeTc$
----------	---

B38G5L Technical Data Sheet



COMPRESSOR DIMENSIONS

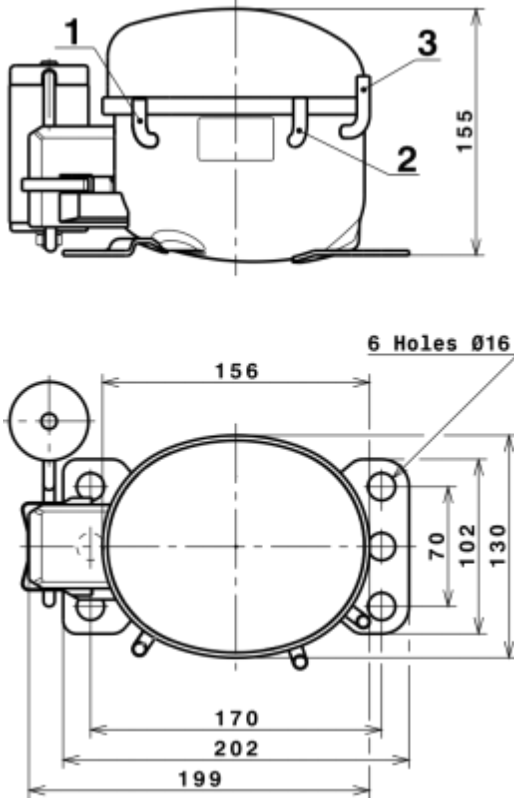

	DESIGNATION	INTERNAL DIAM.
1	Suction	6,1 mm
2	Service	6,1 mm
3	Discharge	5,1 mm

WIRING DIAGRAMS AND ELECTRICAL ASSEMBLY

CSIR CONNECTION (B, Small L ranges)

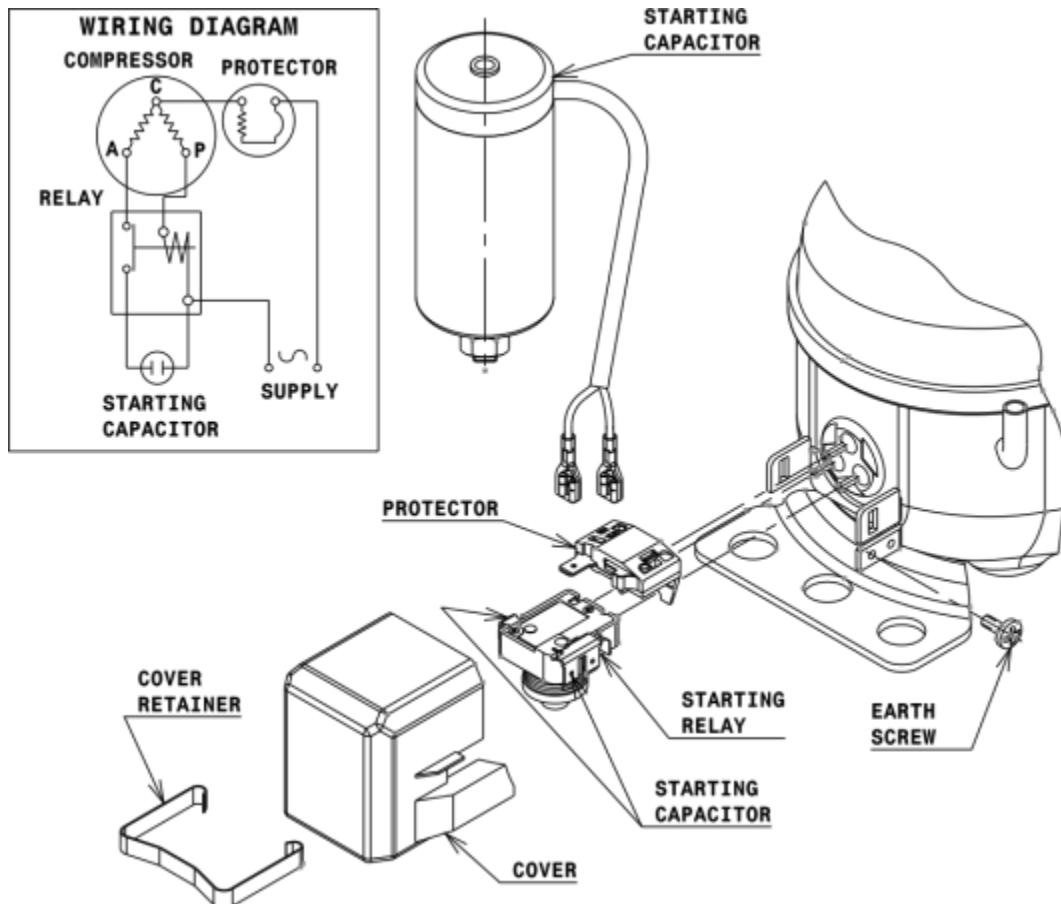

B38G5L Technical Data Sheet

FIXINGS

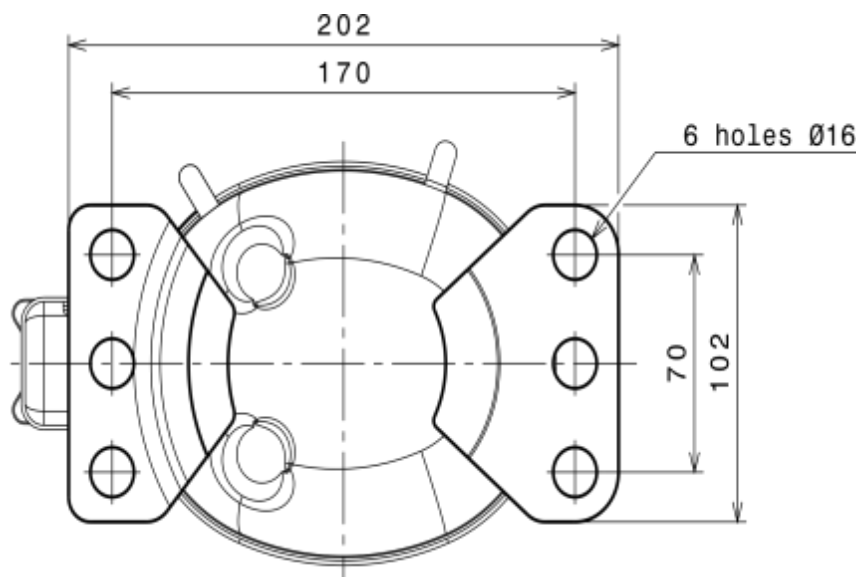

SILENT BLOCKS (MOUNTING ACCESSORIES)

STANDARD

Ø16 holes (170x70 net)

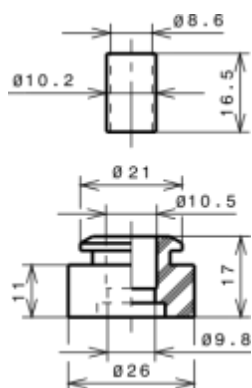

SOA

SOA R134a HBP

