

B38H5 Technical Data Sheet

Compressor model **B38H5**
 Voltage **110-115V 60Hz ~1**
 Refrigerant **R134a**

APPLICATION		COMPRESSOR	MOTOR
Application	Low Back Pressure	Displacement 3,80 cm ³	Nominal Power 1/7 hp
Refrigerant	R134a	Diameter 19,00 mm	Voltage/Frequency 110-115V 60Hz
Evaporating Temp.	-35,0 °C to -15,0 °C	Stroke 6,70 mm	Voltage range 94-127 V
Expansion	Capillar	Net Weight 5,00 Kg	Type RSIR
Comp. Cooling	Static	Oil type ISO VG 15 ESTER	Phase number 1 PH
Max. ambient temp.	43,0 °C	Oil charge 120 cm ³	Max. Cont. Current (MCC) 1,83 A
Compatible refriger.	R1234yf		Main W. resist. at 25°C 7,60 Q
			Start W. resist. at 25°C 1,84 Q

NOMINAL PERFORMANCE

	ASHRAE	CECOMAF
Cooling Capacity	83 kCal/h	72 W
COP	1,11 W/W	0,87 W/W
EER	0,95 kCal/Wh	0,75 kCal/Wh
Input Power	87 W	83 W
Current	1,25 A	1,22 A

TEST CYCLE CONDITIONS

	ASHRAE LBP (B)	CECOMAF LBP (A)
Evaporating temp. (T _e)	-23,3 °C	-25,0 °C
Condensing temp. (T _c)	55,0 °C	55,0 °C
Liquid temp. (T _{liq.})	32,0 °C	55,0 °C
Ambient temp. (T _{amb.})	32,0 °C	32,0 °C
Suction temp. (T _{suction})	32,0 °C	32,0 °C
Voltage/Frequency	115 V 60 Hz	115 V 60 Hz

ELECTRICAL COMPONENTS

Relay	Option 1	Option 2		
Reference	JPQII-4.7 (010)	QP2-4R7 (010)		
Voltage	V	110-120 V		
Resistance	Q	Q		
Protector	Option 1	Option 2		
Reference	BT66-125 (039)	DRB235P61A1 (039)		
Current				
Time check				
Disc temp. (Open/Close)				

B38H5 Technical Data Sheet



ASHRAE

Tc °C	Te °C	Cooling Capacity kCal/h	Consumption W	Current A	COP W/W	EER kCal/Wh
40	-35	40	63	1,08	0,74	0,63
40	-30	61	71	1,14	1,00	0,86
40	-25	83	81	1,21	1,20	1,03
40	-23,3	91	84	1,23	1,25	1,08
40	-20	106	92	1,28	1,34	1,16
40	-15	130	104	1,38	1,45	1,25
40	-10	154	117	1,48	1,53	1,32

45	-35	39	62	1,08	0,72	0,62
45	-30	59	71	1,14	0,97	0,83
45	-25	81	81	1,21	1,15	0,99
45	-23,3	88	85	1,24	1,20	1,03
45	-20	103	93	1,29	1,29	1,11
45	-15	126	106	1,39	1,39	1,19
45	-10	150	120	1,51	1,46	1,25

50	-35	37	62	1,07	0,70	0,61
50	-30	57	71	1,14	0,94	0,81
50	-25	78	82	1,21	1,11	0,95
50	-23,3	86	86	1,24	1,16	0,99
50	-20	100	94	1,30	1,23	1,06
50	-15	123	108	1,41	1,32	1,14
50	-10	146	122	1,53	1,39	1,19

55	-35	36	61	1,07	0,69	0,59
55	-30	56	71	1,14	0,91	0,78
55	-25	76	83	1,22	1,07	0,92
55	-23,3	83	87	1,25	1,11	0,95
55	-20	97	96	1,31	1,18	1,02
55	-15	119	110	1,42	1,26	1,09
55	-10	142	125	1,55	1,32	1,14

60	-35	35	60	1,07	0,67	0,57
60	-30	54	71	1,14	0,88	0,75
60	-25	73	83	1,22	1,02	0,88
60	-23,3	80	88	1,26	1,06	0,91
60	-20	94	97	1,32	1,13	0,97
60	-15	116	112	1,44	1,20	1,04
60	-10	138	128	1,57	1,26	1,08

65	-35	33	60	1,06	0,65	0,56
65	-30	52	71	1,14	0,85	0,73
65	-25	71	84	1,23	0,98	0,85
65	-23,3	78	89	1,26	1,02	0,88
65	-20	91	98	1,33	1,08	0,93
65	-15	112	114	1,46	1,15	0,99
65	-10	134	130	1,60	1,20	1,03

CECOMAF

Tc °C	Te °C	Cooling Capacity W	Consumption W	Current A	COP W/W	EER kCal/Wh
40	-35	44	63	1,08	0,69	0,60
40	-30	67	71	1,14	0,94	0,81
40	-25	91	81	1,21	1,13	0,97
40	-23,3	99	84	1,23	1,18	1,02
40	-20	116	92	1,28	1,26	1,09
40	-15	141	104	1,38	1,36	1,18
40	-10	168	117	1,48	1,43	1,24

45	-35	40	62	1,08	0,65	0,56
45	-30	62	71	1,14	0,87	0,75
45	-25	85	81	1,21	1,04	0,90
45	-23,3	92	85	1,24	1,08	0,94
45	-20	108	93	1,29	1,16	1,00
45	-15	132	106	1,39	1,25	1,08
45	-10	156	120	1,51	1,31	1,13

50	-35	37	62	1,07	0,60	0,52
50	-30	57	71	1,14	0,80	0,69
50	-25	78	82	1,21	0,95	0,82
50	-23,3	85	86	1,24	0,99	0,86
50	-20	100	94	1,30	1,06	0,91
50	-15	122	108	1,41	1,13	0,98
50	-10	145	122	1,53	1,19	1,02

55	-35	34	61	1,07	0,56	0,48
55	-30	52	71	1,14	0,74	0,64
55	-25	72	83	1,22	0,87	0,75
55	-23,3	78	87	1,25	0,90	0,78
55	-20	92	96	1,31	0,96	0,83
55	-15	112	110	1,42	1,02	0,89
55	-10	134	125	1,55	1,07	0,93

60	-35	31	60	1,07	0,51	0,44
60	-30	48	71	1,14	0,67	0,58
60	-25	65	83	1,22	0,78	0,68
60	-23,3	71	88	1,26	0,81	0,70
60	-20	84	97	1,32	0,86	0,75
60	-15	103	112	1,44	0,92	0,80
60	-10	123	128	1,57	0,96	0,83

65	-35	28	60	1,06	0,46	0,40
65	-30	43	71	1,14	0,60	0,52
65	-25	59	84	1,23	0,70	0,60
65	-23,3	64	89	1,26	0,73	0,63
65	-20	76	98	1,33	0,77	0,66
65	-15	93	114	1,46	0,82	0,71
65	-10	111	130	1,60	0,85	0,74

EN12900

X	Cooling Capacity (W)	Consumption (W)	Current (A)	Mass Flow (kg/h)
1	337,7178358975	118,4476795507	1,5049772182	5,9009428044597
2	8,2152922467	2,3133495008	0,0213072022	0,15185052532318
3	-2,9650837457	0,8189893063	0,0068104522	-0,024212732032522
4	0,0150605863	0,0263855084	0,0003010601	0,00049008118740912
5	-0,0662717858	0,0272911339	0,0002202647	-0,00051323064652659

Equation	$x_1 + x_2Te + x_3Tc + x_4Te^2 + x_5TeTc$
----------	---

B38H5 Technical Data Sheet

COMPRESSOR DIMENSIONS

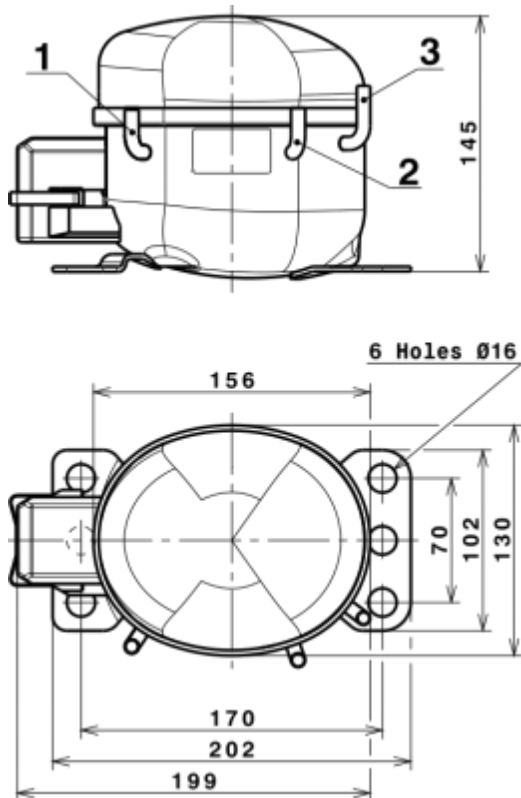

	DESIGNATION	INTERNAL DIAM.
1	Suction	6,1 mm
2	Service	6,1 mm
3	Discharge	5,1 mm

WIRING DIAGRAMS AND ELECTRICAL ASSEMBLY

RSIR CONNECTION (PTC) (B, Small L ranges)

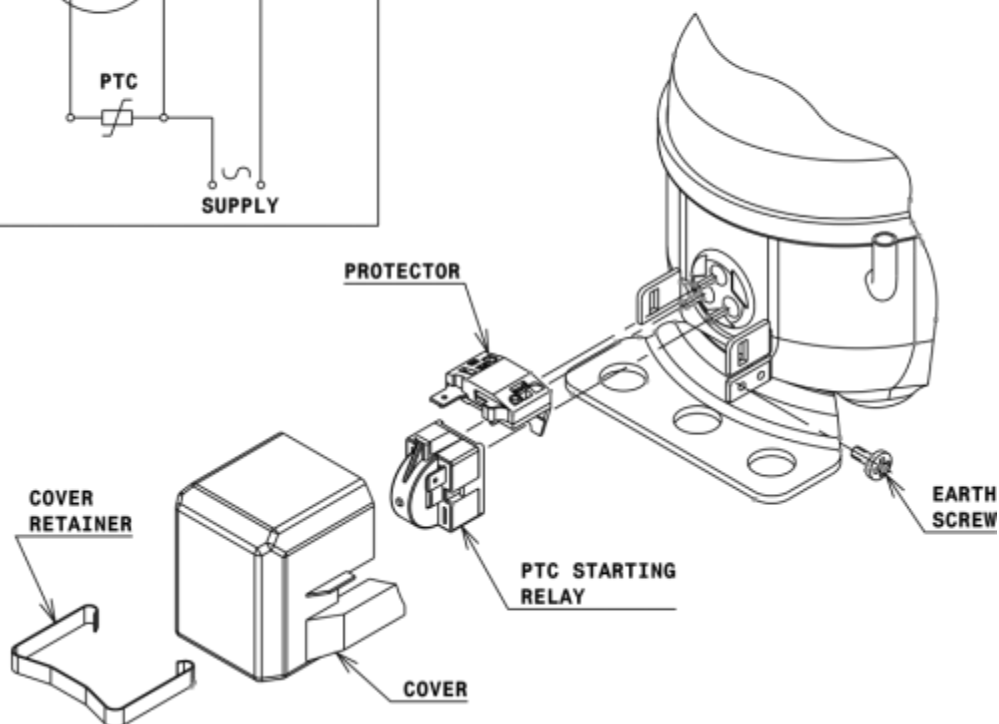
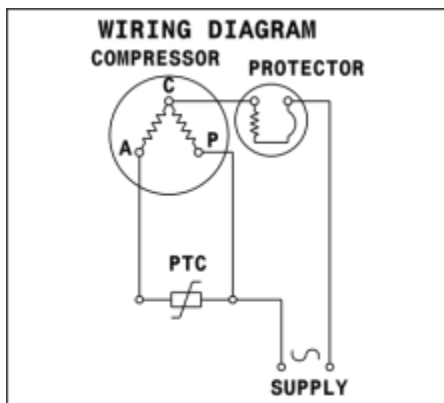

B38H5 Technical Data Sheet

FIXINGS

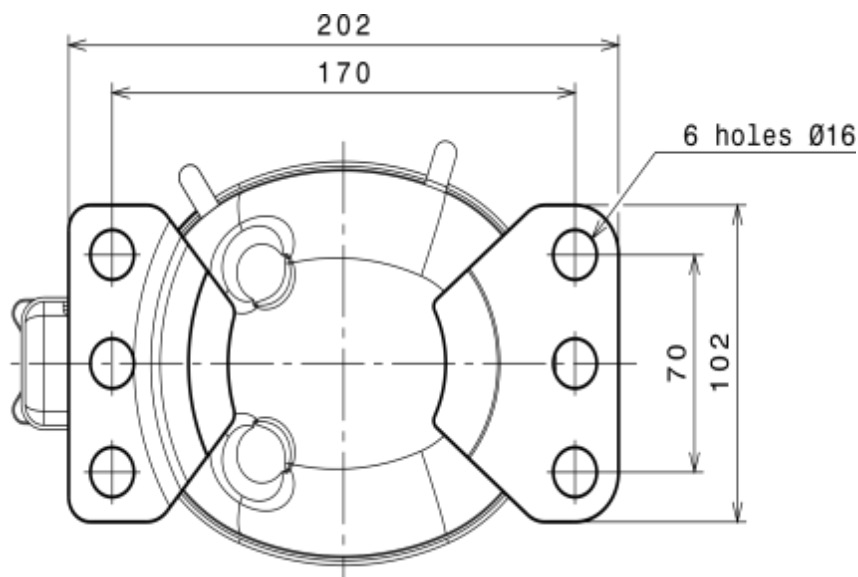

SILENT BLOCKS (MOUNTING ACCESSORIES)

STANDARD

Ø16 holes (170x70 net)

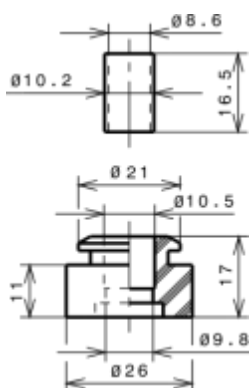

SOA

SOA R134a LBP

